



Installation Instructions for Steel, Wood or Fiberglass Doors

3/1/06

Tool List:

Hammer, screwdriver, all-purpose caulk, plumb-bob, rule or measure, 6' level, square, drill, countersink, nails, marking pen, shims, finish coat and brush for its application

Caution: *Please remember to always transport and store the All Seasons Door system in an upright position and to keep it dry until it is correctly installed and weather protected. Failure to follow proper installation instructions and/or failure to finish the unit promptly before exposure to weather will void warranty. Be sure to install the door under a wide overhang for protection. A minimum of 4' is recommended. Installing your new All Seasons Door will take time and careful attention. There are no shortcuts. Follow these instructions carefully and you will have a beautiful door that will give you years of trouble free service.*

Step 1 The Opening:

Using your level, and your square, see how level and square the rough opening is.

For example, the top or head and side walls of the rough opening may not be square, or perpendicular to each other.

Or the rough opening might be in parallelogram shape. Still another condition to look for in your rough opening is twist. Making correct adjustments on our door unit as it is installed can compensate for all of these common problems. Remember your door must be installed level, square, and plumb within the rough wall opening to operate as it was designed.

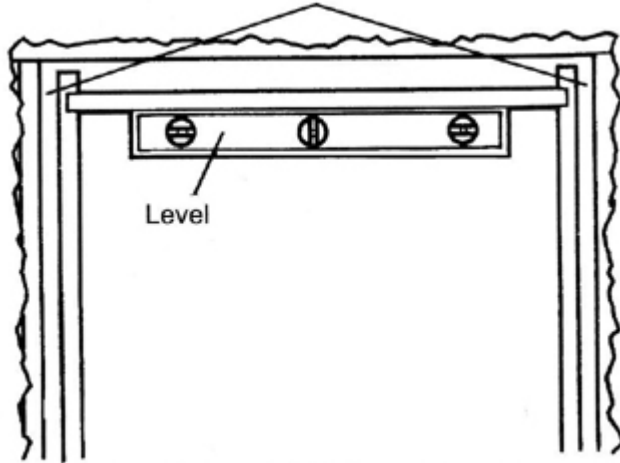

Visually center the top of this frame in the door rough opening. Carefully level the top of the door frame.

Step 2 Getting the Door Ready:

Remove the skid board from beneath the sill or your door, sometimes this is two pieces of board, sometimes one. The plastic clips on the doors that have held the doors closed during shipping must also be removed. Run three 1/4" lines of all-purpose caulking compound along the full width of the bottom of the rough opening or sub-floor and one 1/4" caulk line at each jamb to cover the entire base of the jamb. Set your door unit in the rough opening, pushing in both bottom corners and sides until the exterior trim of the door unit is flush against the outside wall.

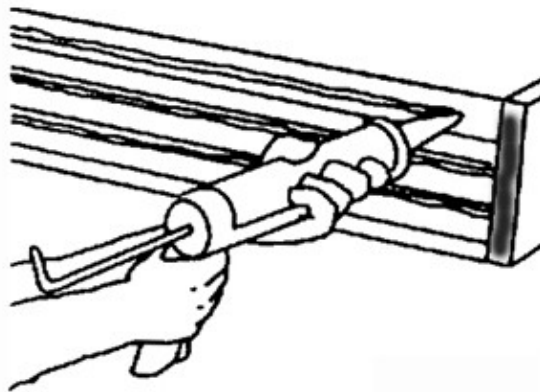

Step 3 Measuring the Fit:

While someone holds the door keeping the exterior trim snug against the exterior wall, take your long level and check to make sure the bottom is still level, and that the head & jamb of the unit is level.

Next, go inside and check the amount of space between the door and the jamb. Move the unit to allow the margins to become more even between the door and the jamb on each side.

Returning to the exterior side of the unit, secure the unit by driving two 2 1/2" finish nails, one into each upper corner trough the exterior trim and into the wall. Leave about 1/2" of the nail out (these are to be removed once the installation screws have been installed in each hinge). With the door temporarily held in place, push open the doors and see how they operate. If there is any sticking or binding, or if they swing shut or open by themselves, your door is not hanging level, square and plumb and adjustments are needed to make it operate properly.

If the doors are sticking or won't close properly, return to the interior side of your door. Look for areas where there is too much space, and areas where there is too little space. Shift the door one way or the other to even up; the margins around the door and insert shims to hold the door unit in position. Push or pull the bottom of your door until the door is level vertically and square or perpendicular to its own unit head jamb.

Check the lock set holes to see that they are aligned. When everything checks out level, square, and plumb, and your door is operating smoothly, place shims behind each hinge to fill the margin of space between the door unit jamb and the rough opening. And across the top of the head jamb at three equally spaced areas.

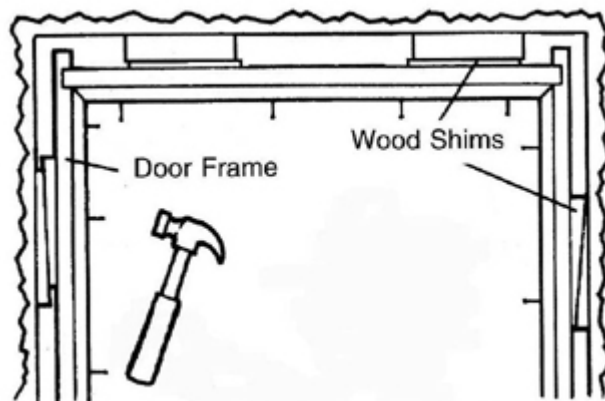

Drive finishing nails near each hinge location.

Step 4 Securing the Door:

Secure your door unit permanently into the rough opening by driving 2 1/2" nails through the jambs and shims where you have inserted them, securing them to the studs of the rough opening. Drive nails flush and set them 1/8" deep with your countersink or nail set for finishing.

Remove two screws from the top hinge on each side jamb of the door unit and replace with the long wood screws provided. These are to be used in each hinge and will extend through the door unit side jamb and into the wall studs of the opening. Pay special

attention when shimming. Your shims must fill up the void behind the jamb to create a solid nailing surface. If you fail to shim properly and leave open space, the door unit will be pulled toward the rough opening.

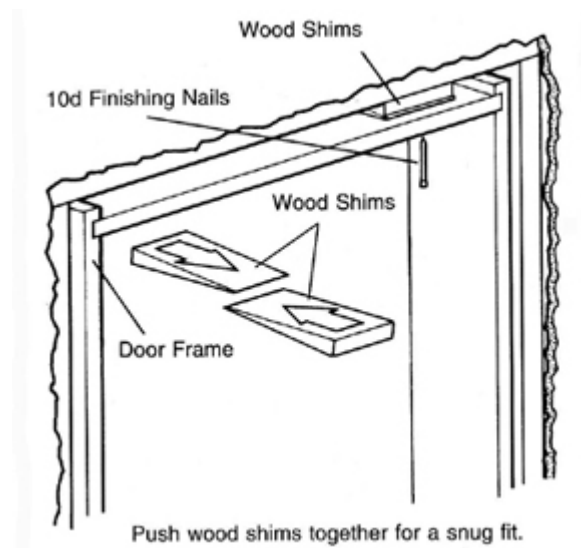

The adjustable threshold may be adjusted as necessary, using a #3 Phillips bit only. There are bolts both at the top and bottom of a double door. After setting the door level, predrill the bolt holes on both the header and sill. Check and make sure these bolts slide into those holes and operate smoothly. Caulk along the sides and top of your door where the exterior trim rests against the house. Make sure there's a tight seal to prevent water entering the wall cavity between the door unit and the rough opening.

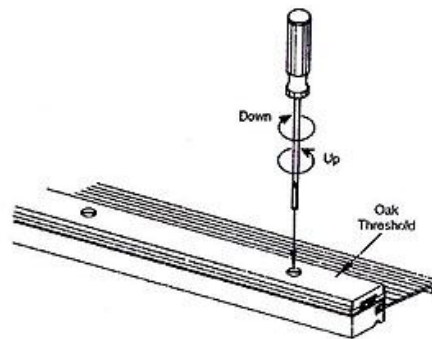

[\(Return to top\)](#)

Step 5 Finishing:

For a steel or fiberglass door, insert screw covers, provided in the packet attached to your door, over the screw heads around the glass insert. For a wood door, fill the brad holes around the panels and glass frames. At this point, your installation is complete except for the very important step of applying a proper finishing coat to all surfaces of your new door unit. **NOTE: The white frames on a steel or smooth skin fiberglass door will**

need to be primed with a plastic primer #AIM Plastic and Vinyl Bonding Primer. Finish with an oil based varnish. Plastic products should be painted with a light color paint. Exposure to high ambient temperatures, such as between a storm door, will void your All Seasons Door Warranty.

A proper finish is crucial when installing a wood door. This preserves the door surface and without a proper finish your door can be damaged by the elements. Grain sealer is required for wood All Seasons Doors to Warrant its product and all six sides (both faces, hinge side, lock side, top, and bottom of the slab) must be sealed. Failure to properly finish your door will void the door unit's warranty. Wood does have color variances and can be brought to a closer match with a proper stain. Be sure to clear coat with a minimum of 3 coats of a marine type varnish, with a UV inhibitor.

Now is the time to install your lock set following the lock manufacturers directions

Troubleshooting Tips:

If you've finished installing your French door and its not opening and closing smoothly check the following:

- Make sure your margins are even along the head jamb, side jambs and sill of your doors. If they are not, shim to shift the door so it is level square and plumb.
- If your door swings open or closed by itself, it may not be aligned vertically. This indicates incorrect installation or load shift or settling of the house. Carefully remove nails and repeat installation procedure.
- Use proper flashing around the door to prevent leakage. Always use the recommended installation procedure for flashing.
- Verify that each hinge has a 3" screw installed with the threads at least 1 ¼" into the framing stud.



400 Ambassador Row
Longview, Tx 75604
1-800-752-7274